



SERVICE YOU CAN TRUST

Single Width Tower 1.8m Long x 0.85m Wide	Working Height 3.2m	Platform Height 1.2m
---	-------------------------------	--------------------------------

Tower Components

Item	Description	Quantity
1	150mm Locking Caster	4
2	Adjustable Leg 500mm	4
3	1m 4 Rung Frame	0
4	1.5m 6 Rung Frame	0
5	2m 8 Rung Frame	2
6	1.8m Trapdoor Platform	1
7	1.8m Fixed Platform	0
8	1.8m Horizontal Brace	6
9	2.1m Diagonal Brace	2
10	Complete Toe Board Set	1
11	S1 Stabiliser	0
12	S2 Stabiliser	0
13	Instruction Manual & EN1004:-1:2020 certificate of conformity	1

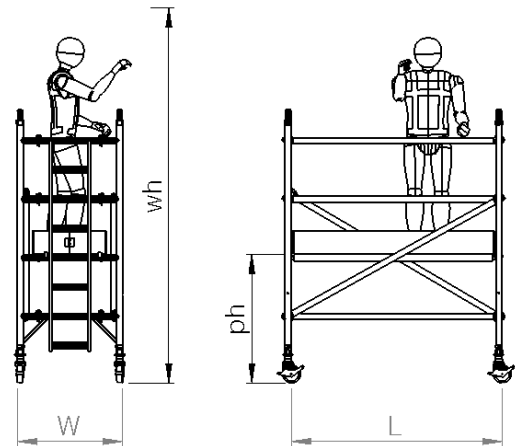
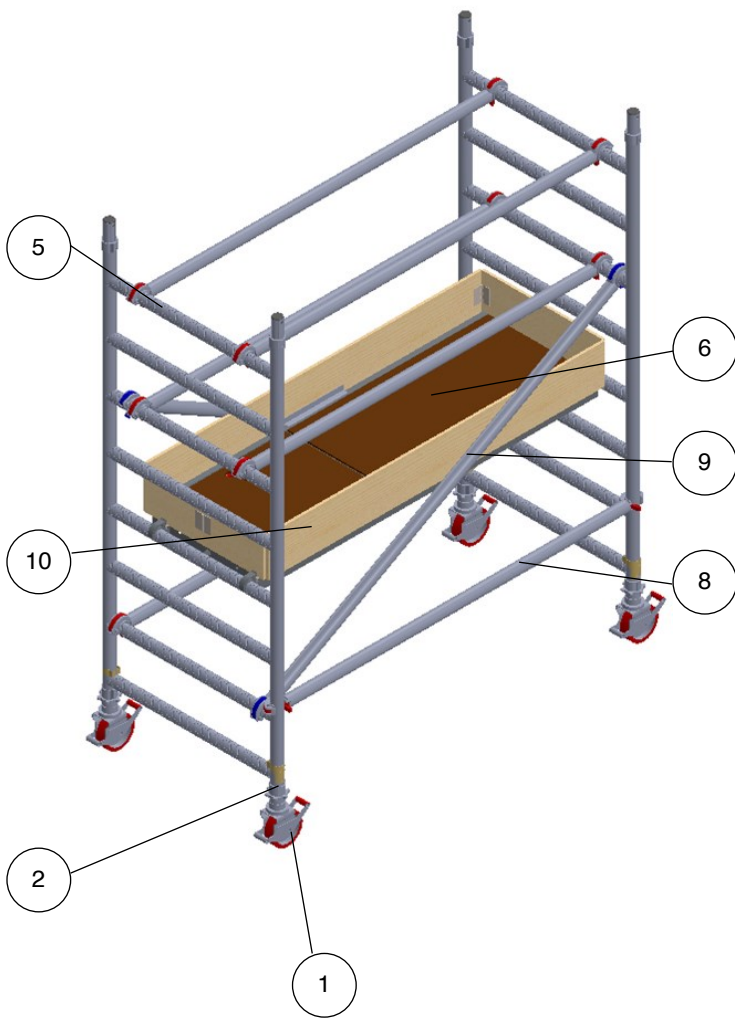

Technical information:

Base Dimensions:	(L)1.8m X (W)0.85m
Maximum Platform Height (ph):	1.2m
Maximum Working Height (wh):	3.2m
Maximum Working Load Per Platform:	275kg
Maximum Working Load Per Tower: (including tower weight)	950kg
Weight:	74.2kg

Mr Plant Hire
120 Hertford Road Enfield
London EN3 5AX

☎ 020 8351 3434
✉ info@mrplanthire.co.uk





SERVICE YOU CAN TRUST

Single Width Tower 1.8m Long x 0.85m Wide	Working Height 3.7m	Platform Height 1.7m
---	-------------------------------	--------------------------------

Tower Components

Item	Description	Quantity
1	150mm Locking Caster	4
2	Adjustable Leg 500mm	4
3	1m 4 Rung Frame	2
4	1.5m 6 Rung Frame	2
5	2m 8 Rung Frame	0
6	1.8m Trapdoor Platform	1
7	1.8m Fixed Platform	0
8	1.8m Horizontal Brace	6
9	2.1m Diagonal Brace	3
10	Complete Toe Board Set	1
11	S1 Stabiliser	0
12	S2 Stabiliser	0
13	Instruction Manual & EN1004:-1:2020 certificate of conformity	1

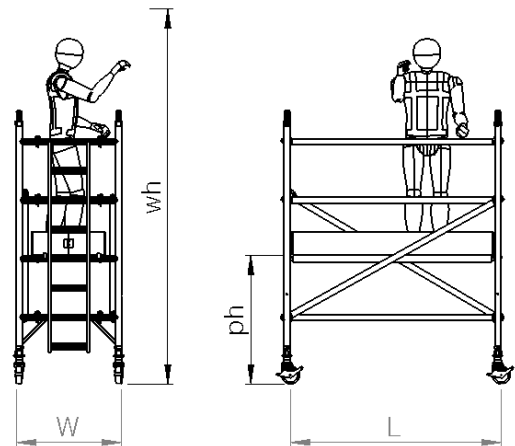
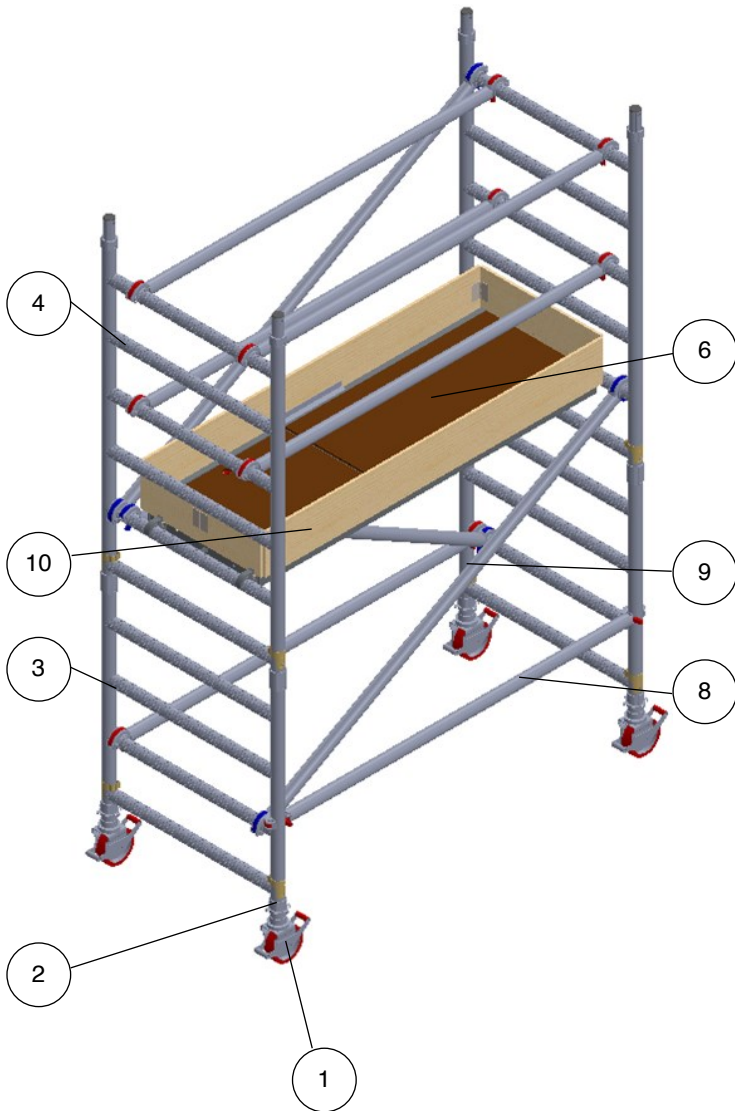

Technical information:

Base Dimensions:	(L)1.8m X (W)0.85m
Maximum Platform Height (ph):	1.7m
Maximum Working Height (wh):	3.7m
Maximum Working Load Per Platform:	275kg
Maximum Working Load Per Tower: (including tower weight)	950kg
Weight:	81.2kg

Mr Plant Hire
120 Hertford Road Enfield
London EN3 5AX

☎ 020 8351 3434
✉ info@mrplanthire.co.uk

BS 8620:2016
TM1005
testandresearch.org

Single Width Tower	Working Height	Platform Height
1.8m Long x 0.85m Wide	4.2m	2.2m

Tower Components

Item	Description	Quantity
1	150mm Locking Caster	4
2	Adjustable Leg 500mm	4
3	1m 4 Rung Frame	2
4	1.5m 6 Rung Frame	0
5	2m 8 Rung Frame	2
6	1.8m Trapdoor Platform	1
7	1.8m Fixed Platform	0
8	1.8m Horizontal Brace	6
9	2.1m Diagonal Brace	3
10	Complete Toe Board Set	1
11	S1 Stabiliser	4
12	S2 Stabiliser	0
13	Instruction Manual & EN1004:-1:2020 certificate of conformity	1

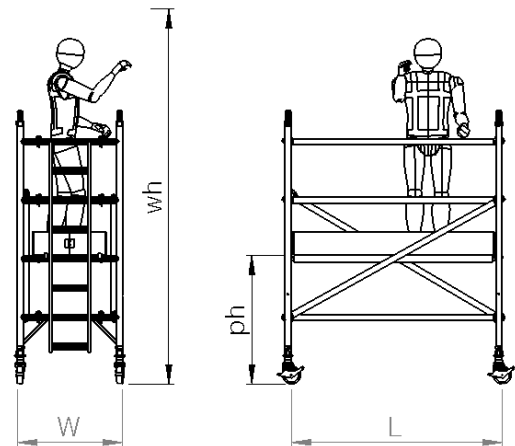
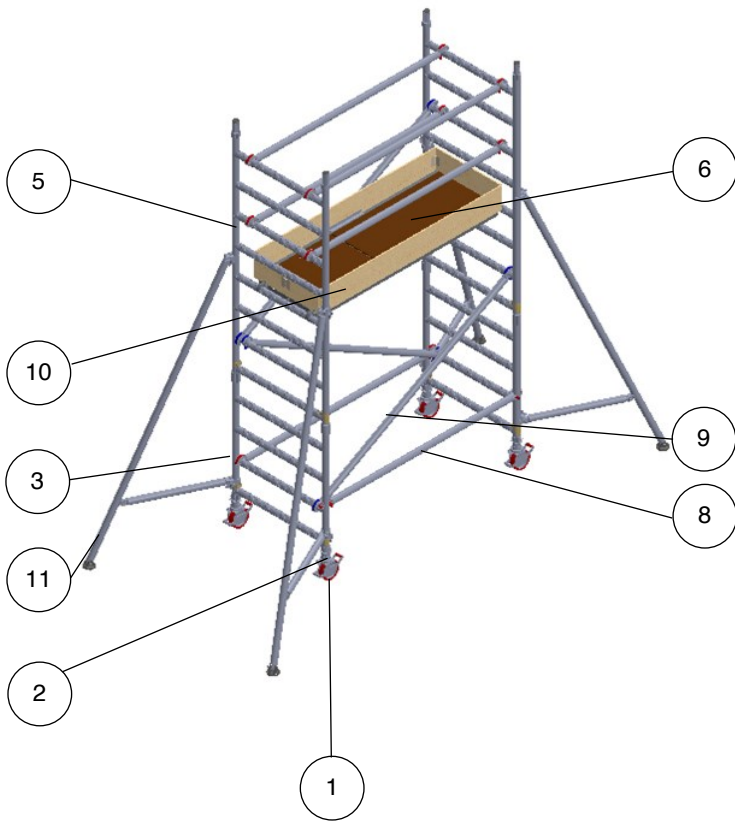

Technical information:

Base Dimensions:	(L)1.8m X (W)0.85m
Maximum Platform Height (ph):	2.2m
Maximum Working Height (wh):	4.2m
Maximum Working Load Per Platform:	275kg
Maximum Working Load Per Tower: (including tower weight)	950kg
Weight:	101.4kg

Single Width Tower	Working Height	Platform Height
1.8m Long x 0.85m Wide	4.7m	2.7m

Tower Components

Item	Description	Quantity
1	150mm Locking Caster	4
2	Adjustable Leg 500mm	4
3	1m 4 Rung Frame	0
4	1.5m 6 Rung Frame	2
5	2m 8 Rung Frame	2
6	1.8m Trapdoor Platform	2
7	1.8m Fixed Platform	0
8	1.8m Horizontal Brace	6
9	2.1m Diagonal Brace	4
10	Complete Toe Board Set	1
11	S1 Stabiliser	4
12	S2 Stabiliser	0
13	Instruction Manual & EN1004:-1:2020 certificate of conformity	1

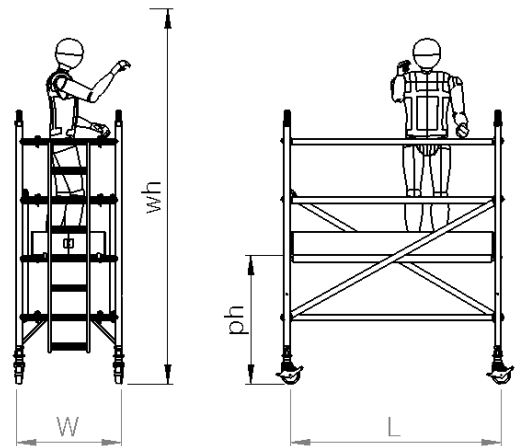
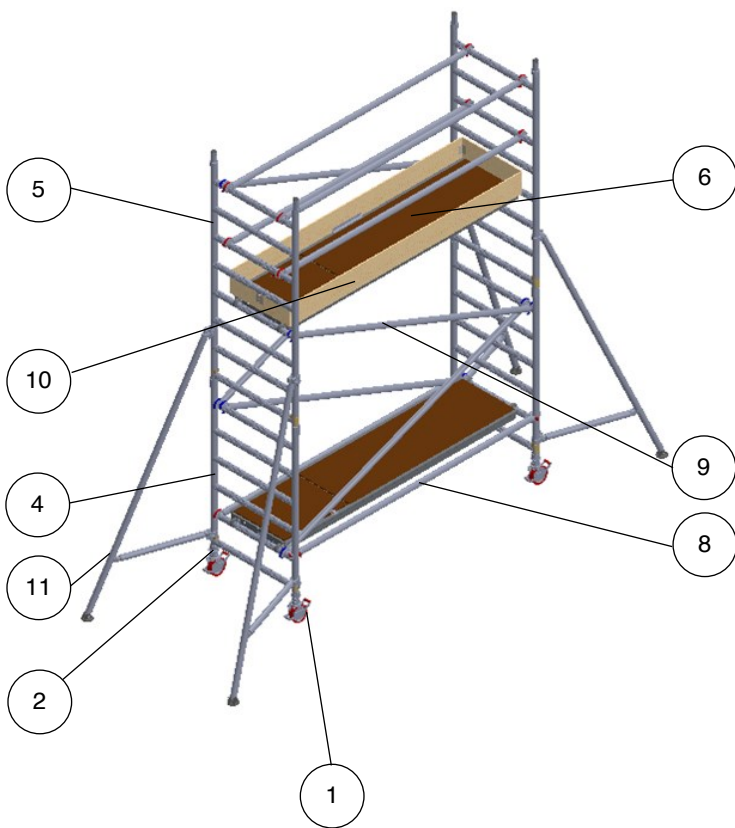

Technical information:

Base Dimensions:	(L)1.8m X (W)0.85m
Maximum Platform Height (ph):	2.7m
Maximum Working Height (wh):	4.7m
Maximum Working Load Per Platform:	275kg
Maximum Working Load Per Tower: (including tower weight)	950kg
Weight:	121.5kg

Single Width Tower 1.8m Long x 0.85m Wide	Working Height 5.2m	Platform Height 3.2m
---	-------------------------------	--------------------------------

Tower Components

Item	Description	Quantity
1	150mm Locking Caster	4
2	Adjustable Leg 500mm	4
3	1m 4 Rung Frame	0
4	1.5m 6 Rung Frame	0
5	2m 8 Rung Frame	4
6	1.8m Trapdoor Platform	2
7	1.8m Fixed Platform	0
8	1.8m Horizontal Brace	10
9	2.1m Diagonal Brace	5
10	Complete Toe Board Set	1
11	S1 Stabiliser	4
12	S2 Stabiliser	0
13	Instruction Manual & EN1004:-1:2020 certificate of conformity	1

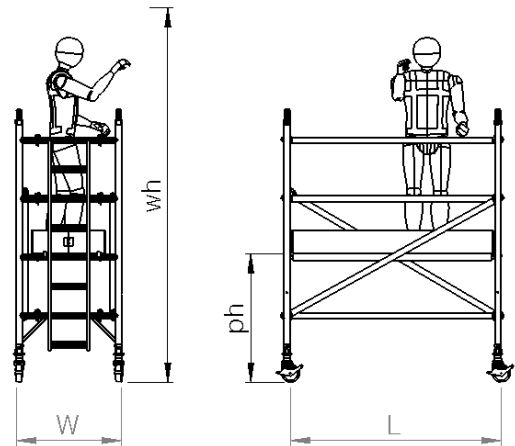
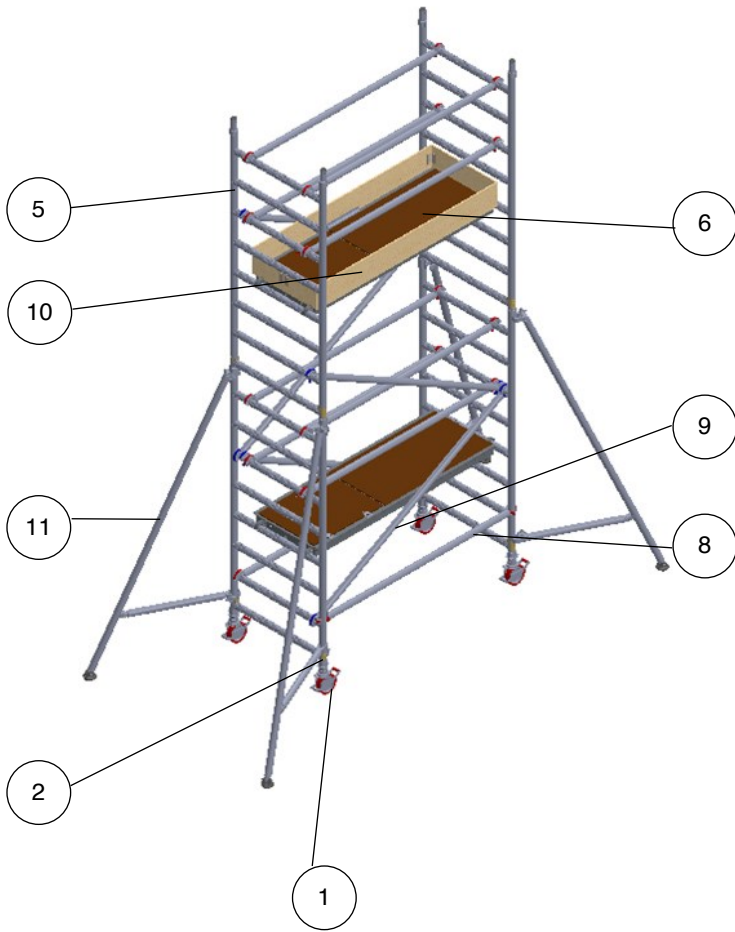

Technical information:

Base Dimensions:	(L)1.8m X (W)0.85m
Maximum Platform Height (ph):	3.2m
Maximum Working Height (wh):	5.2m
Maximum Working Load Per Platform:	275kg
Maximum Working Load Per Tower: (including tower weight)	950kg
Weight:	136.8kg

Single Width Tower 1.8m Long x 0.85m Wide	Working Height 5.7m	Platform Height 3.7m
---	-------------------------------	--------------------------------

Tower Components

Item	Description	Quantity
1	150mm Locking Caster	4
2	Adjustable Leg 500mm	4
3	1m 4 Rung Frame	2
4	1.5m 6 Rung Frame	2
5	2m 8 Rung Frame	2
6	1.8m Trapdoor Platform	2
7	1.8m Fixed Platform	0
8	1.8m Horizontal Brace	10
9	2.1m Diagonal Brace	6
10	Complete Toe Board Set	1
11	S1 Stabiliser	4
12	S2 Stabiliser	0
13	Instruction Manual & EN1004:-1:2020 certificate of conformity	1

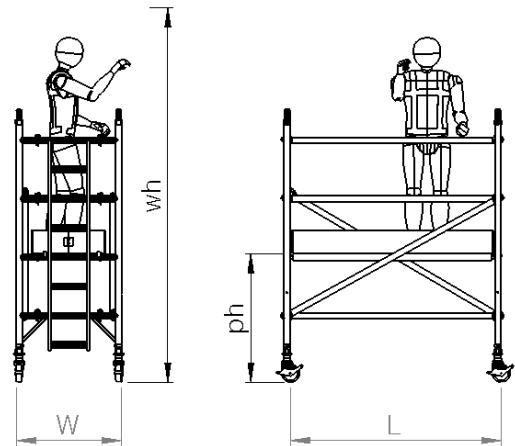
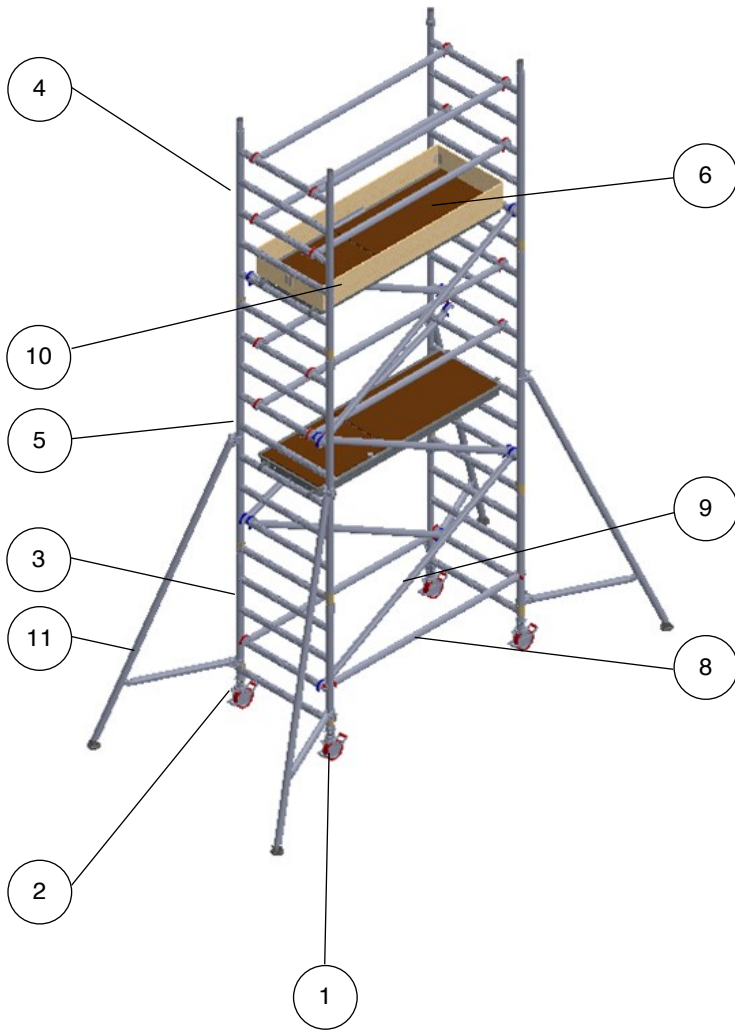

Technical information:

Base Dimensions:	(L)1.8m X (W)0.85m
Maximum Platform Height (ph):	3.7m
Maximum Working Height (wh):	5.7m
Maximum Working Load Per Platform:	275kg
Maximum Working Load Per Tower: (including tower weight)	950kg
Weight:	143.8kg



SERVICE YOU CAN TRUST

Single Width Tower	Working Height	Platform Height
1.8m Long x 0.85m Wide	6.2m	4.2m

Tower Components

Item	Description	Quantity
1	150mm Locking Caster	4
2	Adjustable Leg 500mm	4
3	1m 4 Rung Frame	2
4	1.5m 6 Rung Frame	0
5	2m 8 Rung Frame	4
6	1.8m Trapdoor Platform	2
7	1.8m Fixed Platform	0
8	1.8m Horizontal Brace	10
9	2.1m Diagonal Brace	7
10	Complete Toe Board Set	1
11	S1 Stabiliser	4
12	S2 Stabiliser	0
13	Instruction Manual & EN1004:-1:2020 certificate of conformity	1

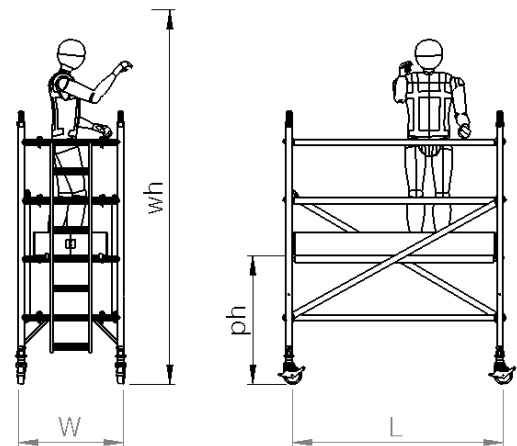
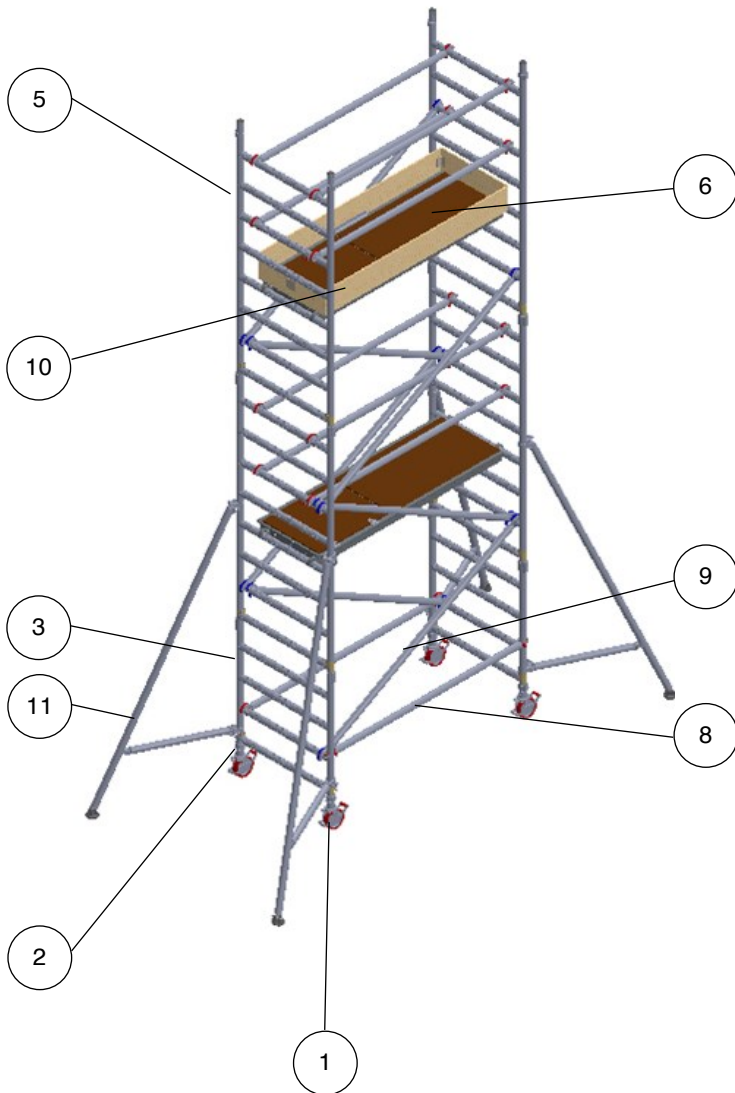

Technical information:

Base Dimensions:	(L)1.8m X (W)0.85m
Maximum Platform Height (ph):	4.2m
Maximum Working Height (wh):	6.2m
Maximum Working Load Per Platform:	275kg
Maximum Working Load Per Tower: (including tower weight)	950kg
Weight:	149.8kg



SERVICE YOU CAN TRUST

Single Width Tower	Working Height	Platform Height
1.8m Long x 0.85m Wide	6.7m	4.7m

Tower Components

Item	Description	Quantity
1	150mm Locking Caster	4
2	Adjustable Leg 500mm	4
3	1m 4 Rung Frame	0
4	1.5m 6 Rung Frame	2
5	2m 8 Rung Frame	4
6	1.8m Trapdoor Platform	3
7	1.8m Fixed Platform	0
8	1.8m Horizontal Brace	10
9	2.1m Diagonal Brace	8
10	Complete Toe Board Set	1
11	S1 Stabiliser	4
12	S2 Stabiliser	0
13	Instruction Manual & EN1004:-1:2020 certificate of conformity	1

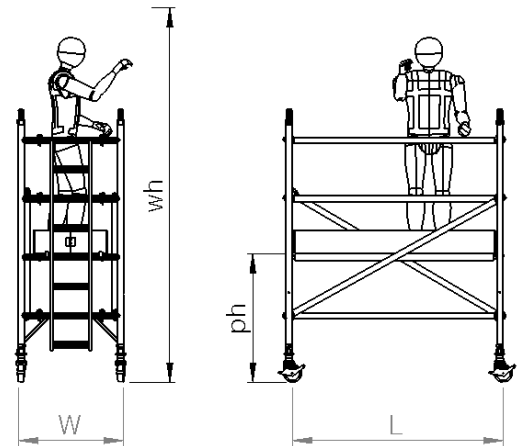
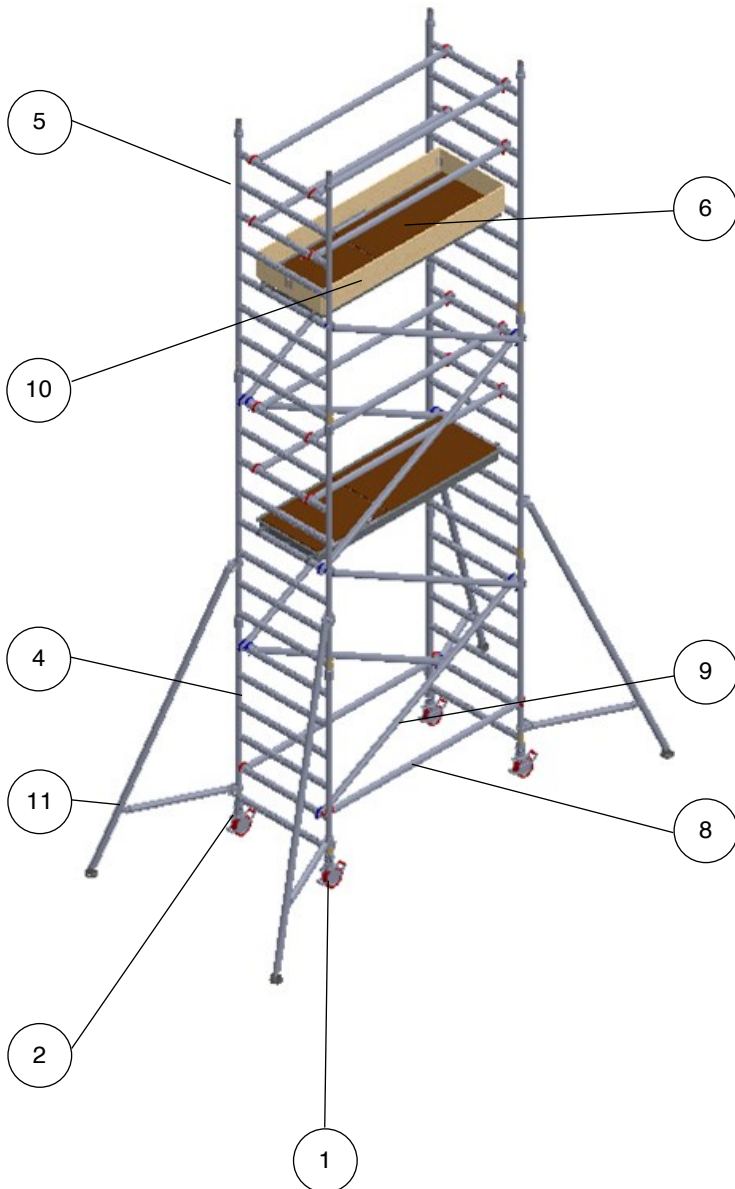

Technical information:

Base Dimensions:	(L)1.8m X (W)0.85m
Maximum Platform Height (ph):	4.7m
Maximum Working Height (wh):	6.7m
Maximum Working Load Per Platform:	275kg
Maximum Working Load Per Tower: (including tower weight)	950kg
Weight:	158.1kg

Mr Plant Hire
120 Hertford Road Enfield
London EN3 5AX

☎ 020 8351 3434
✉ info@mrplanthire.co.uk

BS 8620:2016
TM1005
testandresearch.org



SERVICE YOU CAN TRUST

Single Width Tower 1.8m Long x 0.85m Wide	Working Height 7.2m	Platform Height 5.2m
---	-------------------------------	--------------------------------

Tower Components

Item	Description	Quantity
1	150mm Locking Caster	4
2	Adjustable Leg 500mm	4
3	1m 4 Rung Frame	0
4	1.5m 6 Rung Frame	0
5	2m 8 Rung Frame	6
6	1.8m Trapdoor Platform	3
7	1.8m Fixed Platform	0
8	1.8m Horizontal Brace	14
9	2.1m Diagonal Brace	9
10	Complete Toe Board Set	1
11	S1 Stabiliser	4
12	S2 Stabiliser	0
13	Instruction Manual & EN1004:-1:2020 certificate of conformity	1

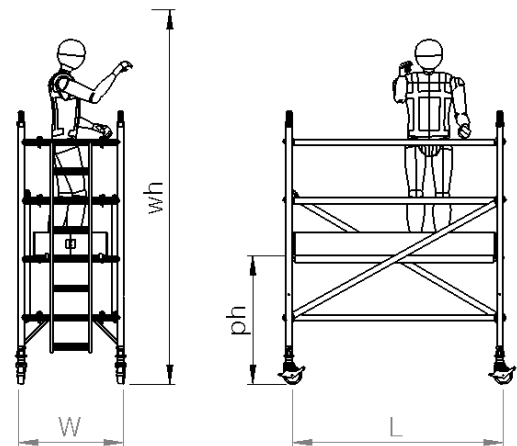
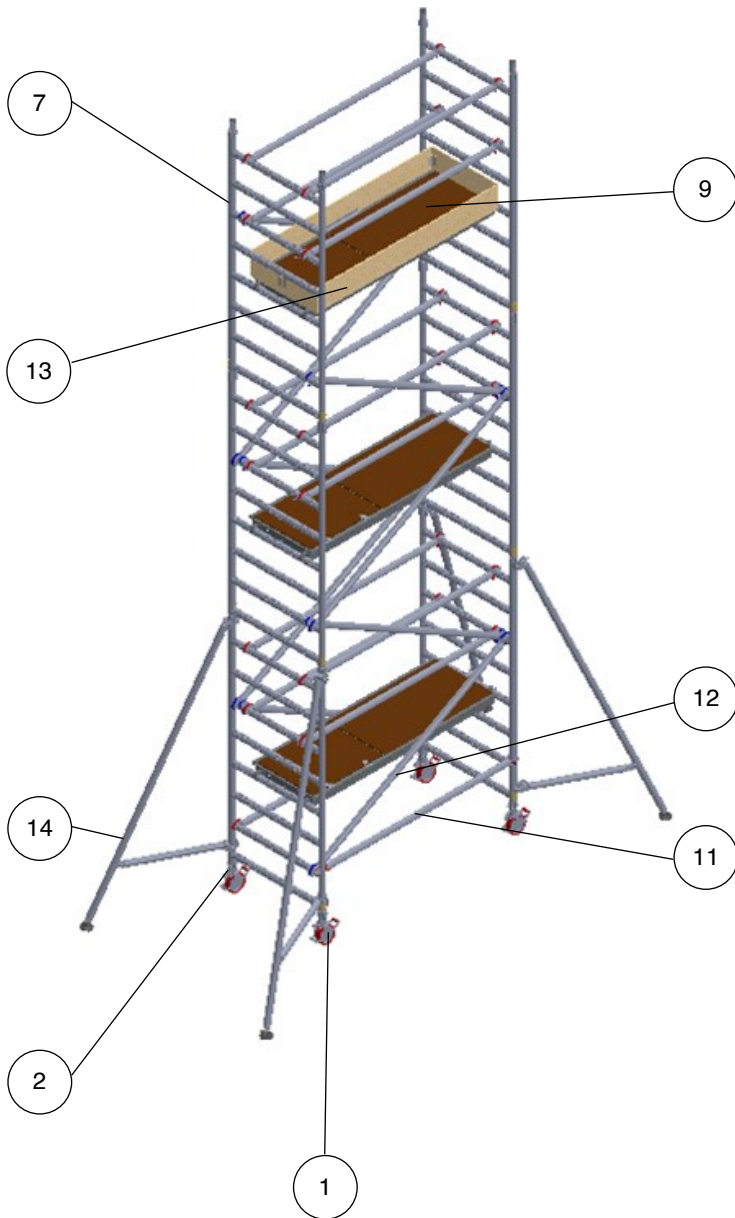

Technical information:

Base Dimensions:	(L)1.8m X (W)0.85m
Maximum Platform Height (ph):	5.2m
Maximum Working Height (wh):	7.2m
Maximum Working Load Per Platform:	275kg
Maximum Working Load Per Tower: (including tower weight)	950kg
Weight:	185.2kg

Mr Plant Hire
120 Hertford Road Enfield
London EN3 5AX

☎ 020 8351 3434
✉ info@mrplanthire.co.uk





SERVICE YOU CAN TRUST

Single Width Tower	Working Height	Platform Height
1.8m Long x 0.85m Wide	7.7m	5.7m

Tower Components

Item	Description	Quantity
1	150mm Locking Caster	4
2	Adjustable Leg 500mm	4
3	1m 4 Rung Frame	2
4	1.5m 6 Rung Frame	2
5	2m 8 Rung Frame	4
6	1.8m Trapdoor Platform	3
7	1.8m Fixed Platform	0
8	1.8m Horizontal Brace	14
9	2.1m Diagonal Brace	10
10	Complete Toe Board Set	1
11	S1 Stabiliser	4
12	S2 Stabiliser	0
13	Instruction Manual & EN1004:-1:2020 certificate of conformity	1

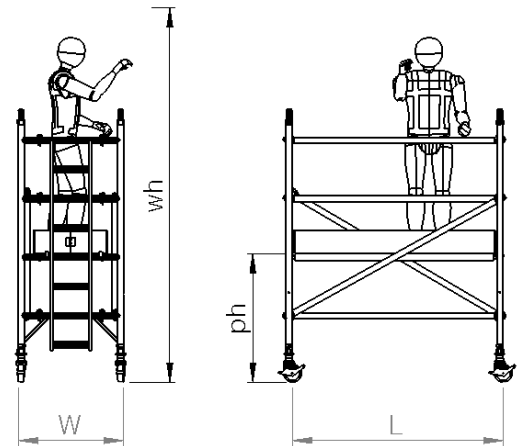
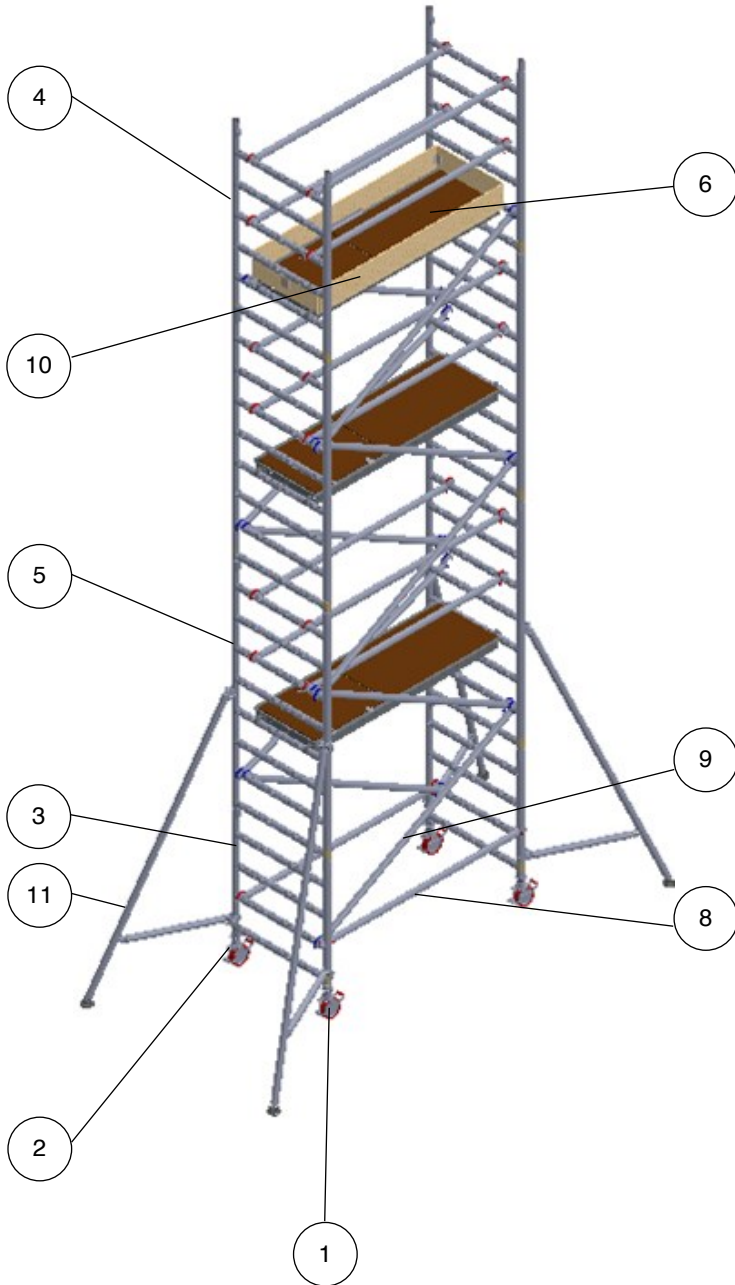

Technical information:

Base Dimensions:	(L)1.8m X (W)0.85m
Maximum Platform Height (ph):	5.7m
Maximum Working Height (wh):	7.7m
Maximum Working Load Per Platform:	275kg
Maximum Working Load Per Tower: (including tower weight)	950kg
Weight:	192.2kg



SERVICE YOU CAN TRUST

Single Width Tower	Working Height	Platform Height
1.8m Long x 0.85m Wide	8.2m	6.2m

Tower Components

Item	Description	Quantity
1	150mm Locking Caster	4
2	Adjustable Leg 500mm	4
3	1m 4 Rung Frame	2
4	1.5m 6 Rung Frame	0
5	2m 8 Rung Frame	6
6	1.8m Trapdoor Platform	3
7	1.8m Fixed Platform	0
8	1.8m Horizontal Brace	14
9	2.1m Diagonal Brace	11
10	Complete Toe Board Set	1
11	S1 Stabiliser	4
12	S2 Stabiliser	0
13	Instruction Manual & EN1004:-1:2020 certificate of conformity	1

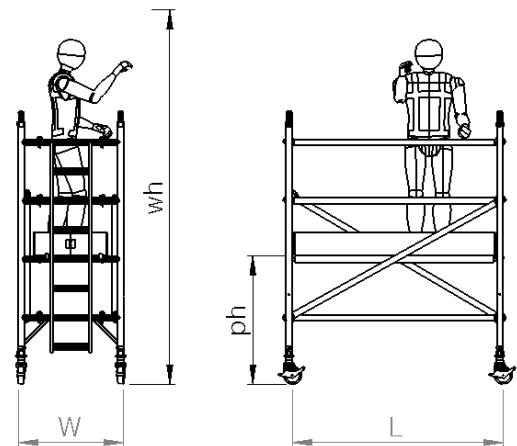
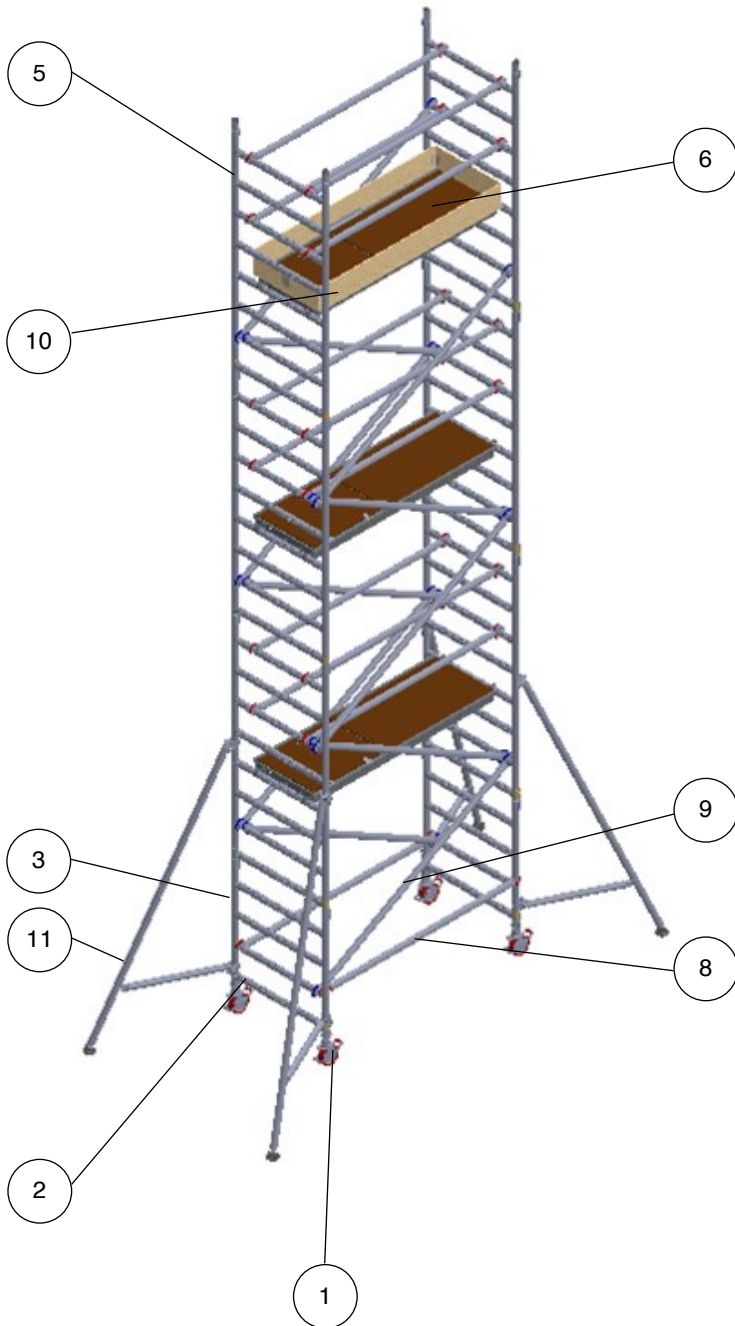

Technical information:

Base Dimensions:	(L)1.8m X (W)0.85m
Maximum Platform Height (ph):	6.2m
Maximum Working Height (wh):	8.2m
Maximum Working Load Per Platform:	275kg
Maximum Working Load Per Tower: (including tower weight)	950kg
Weight:	198.2kg

Mr Plant Hire
120 Hertford Road Enfield
London EN3 5AX

☎ 020 8351 3434
✉ info@mrplanthire.co.uk





SERVICE YOU CAN TRUST

Single Width Tower 1.8m Long x 0.85m Wide	Working Height 8.7m	Platform Height 6.7m
---	-------------------------------	--------------------------------

Tower Components

Item	Description	Quantity
1	150mm Locking Caster	4
2	Adjustable Leg 500mm	4
3	1m 4 Rung Frame	0
4	1.5m 6 Rung Frame	2
5	2m 8 Rung Frame	6
6	1.8m Trapdoor Platform	4
7	1.8m Fixed Platform	0
8	1.8m Horizontal Brace	14
9	2.1m Diagonal Brace	12
10	Complete Toe Board Set	1
11	S1 Stabiliser	4
12	S2 Stabiliser	0
13	Instruction Manual & EN1004:-1:2020 certificate of conformity	1

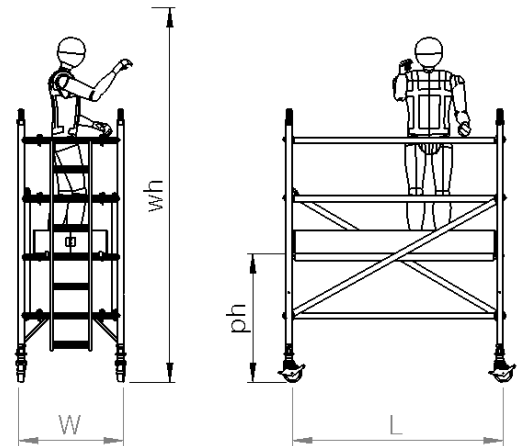
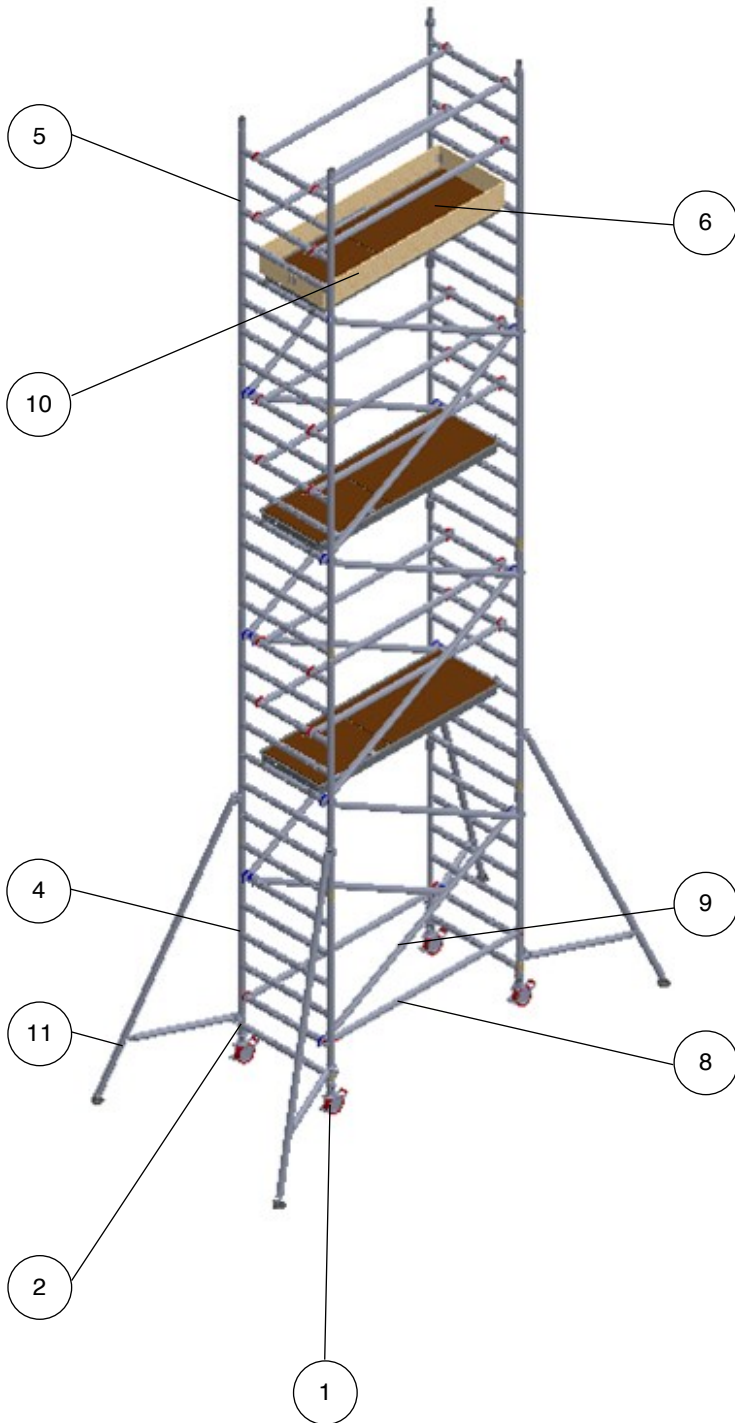

Technical information:

Base Dimensions:	(L)1.8m X (W)0.85m
Maximum Platform Height (ph):	6.7m
Maximum Working Height (wh):	8.7m
Maximum Working Load Per Platform:	275kg
Maximum Working Load Per Tower: (including tower weight)	950kg
Weight:	206.5kg

Single Width Tower 1.8m Long x 0.85m Wide	Working Height 9.2m	Platform Height 7.2m
---	-------------------------------	--------------------------------

Tower Components

Item	Description	Quantity
1	150mm Locking Caster	4
2	Adjustable Leg 500mm	4
3	1m 4 Rung Frame	0
4	1.5m 6 Rung Frame	0
5	2m 8 Rung Frame	8
6	1.8m Trapdoor Platform	4
7	1.8m Fixed Platform	0
8	1.8m Horizontal Brace	18
9	2.1m Diagonal Brace	13
10	Complete Toe Board Set	1
11	S1 Stabiliser	4
12	S2 Stabiliser	0
13	Instruction Manual & EN1004:-1:2020 certificate of conformity	1

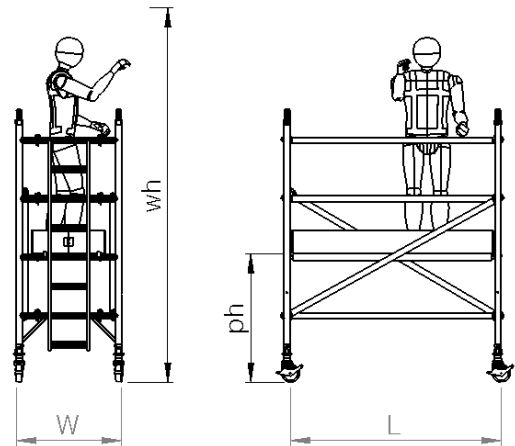
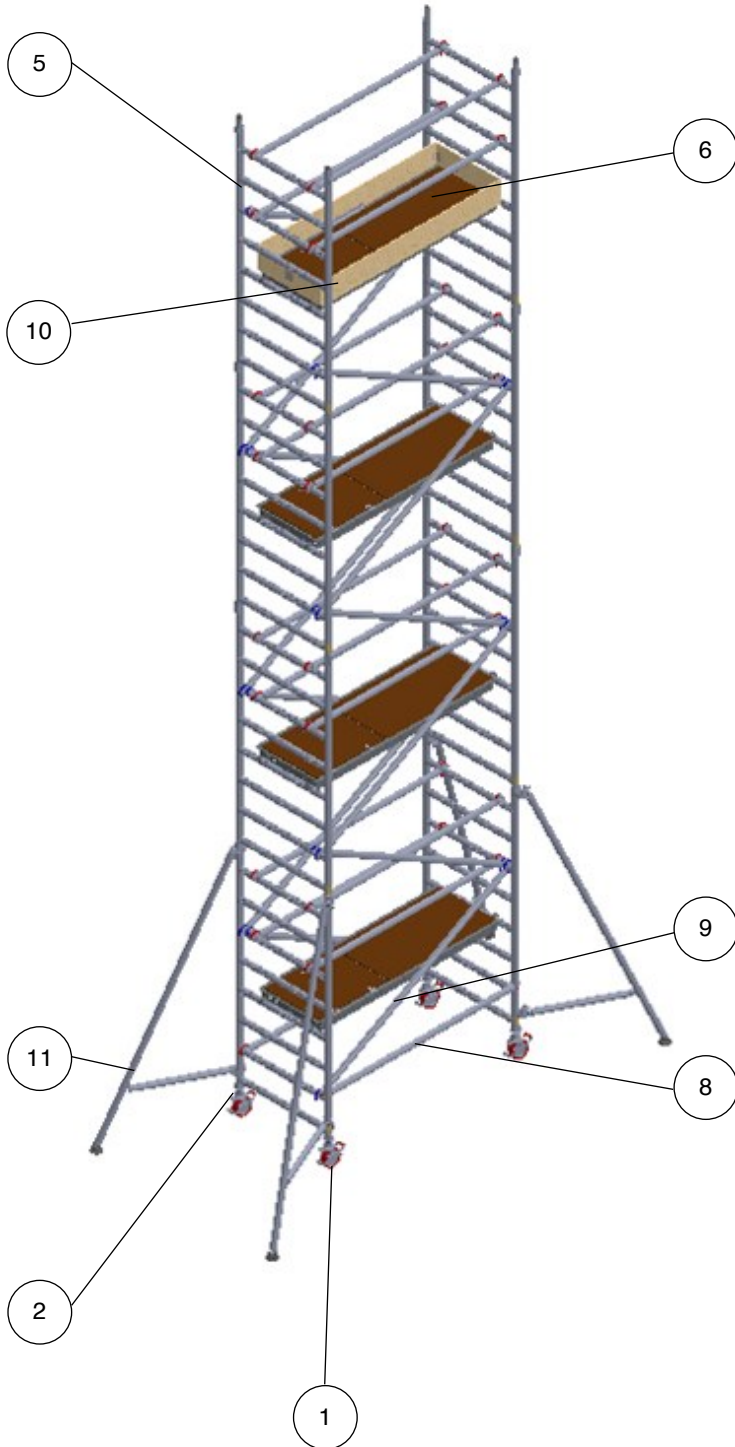

Technical information:

Base Dimensions:	(L)1.8m X (W)0.85m
Maximum Platform Height (ph):	7.2m
Maximum Working Height (wh):	9.2m
Maximum Working Load Per Platform:	275kg
Maximum Working Load Per Tower: (including tower weight)	950kg
Weight:	233.6kg

Single Width Tower 1.8m Long x 0.85m Wide	Working Height 9.7m	Platform Height 7.7m
---	-------------------------------	--------------------------------

Tower Components

Item	Description	Quantity
1	150mm Locking Caster	4
2	Adjustable Leg 500mm	4
3	1m 4 Rung Frame	2
4	1.5m 6 Rung Frame	2
5	2m 8 Rung Frame	6
6	1.8m Trapdoor Platform	4
7	1.8m Fixed Platform	0
8	1.8m Horizontal Brace	18
9	2.1m Diagonal Brace	14
10	Complete Toe Board Set	1
11	S1 Stabiliser	4
12	S2 Stabiliser	0
13	Instruction Manual & EN1004:-1:2020 certificate of conformity	1

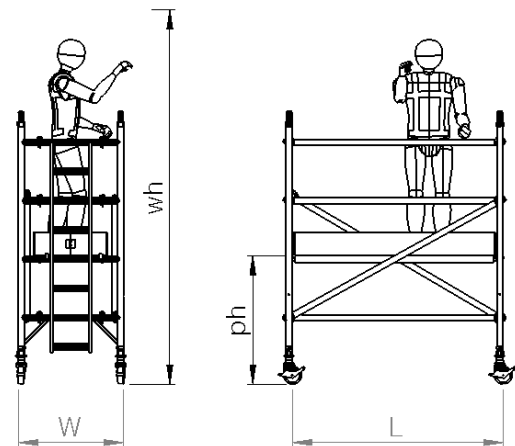
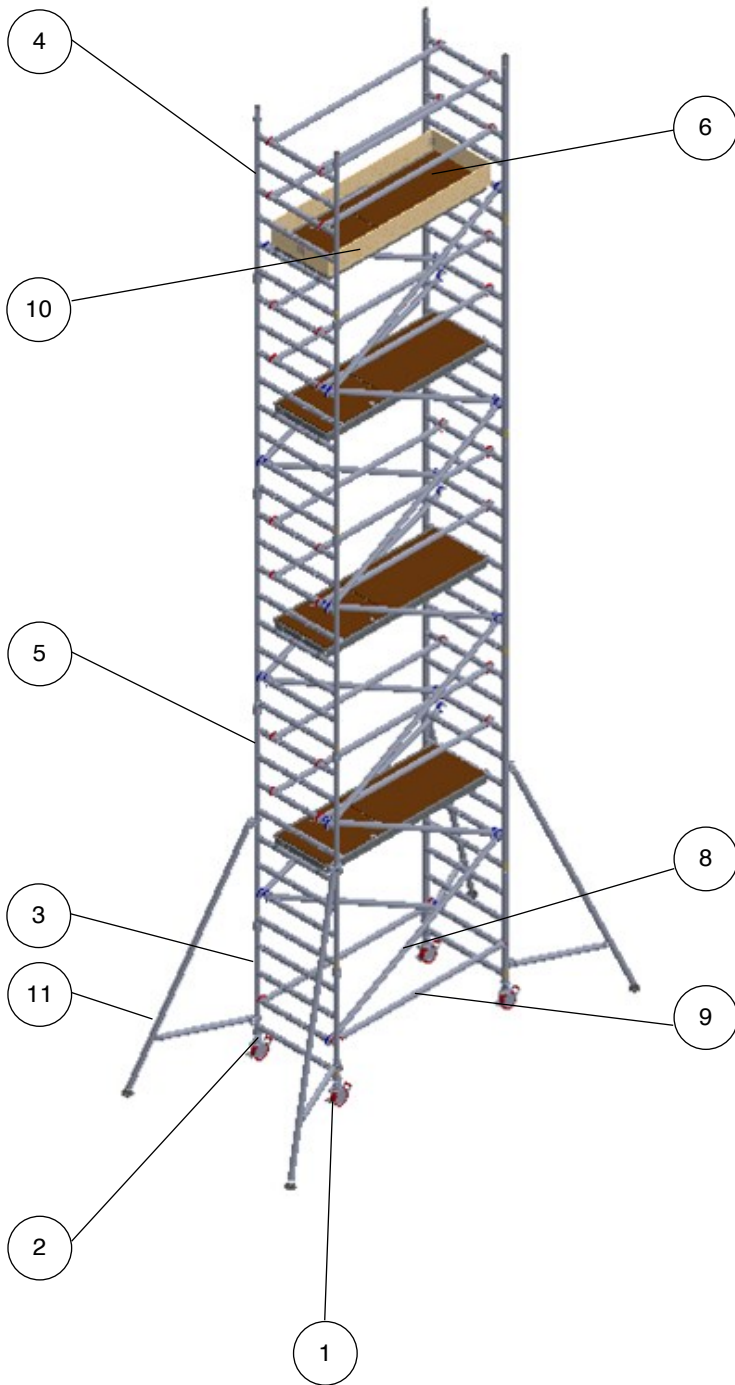

Technical information:

Base Dimensions:	(L)1.8m X (W)0.85m
Maximum Platform Height (ph):	7.7m
Maximum Working Height (wh):	9.7m
Maximum Working Load Per Platform:	275kg
Maximum Working Load Per Tower: (including tower weight)	950kg
Weight:	240.6kg

Single Width Tower	Working Height	Platform Height
1.8m Long x 0.85m Wide	10.2m	8.2m

Tower Components

Item	Description	Quantity
1	150mm Locking Caster	4
2	Adjustable Leg 500mm	4
3	1m 4 Rung Frame	2
4	1.5m 6 Rung Frame	0
5	2m 8 Rung Frame	8
6	1.8m Trapdoor Platform	4
7	1.8m Fixed Platform	0
8	1.8m Horizontal Brace	18
9	2.1m Diagonal Brace	15
10	Complete Toe Board Set	1
11	S1 Stabiliser	4
12	S2 Stabiliser	0
13	Instruction Manual & EN1004:-1:2020 certificate of conformity	1

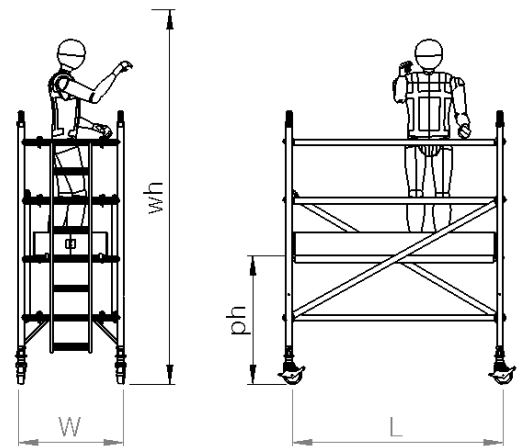
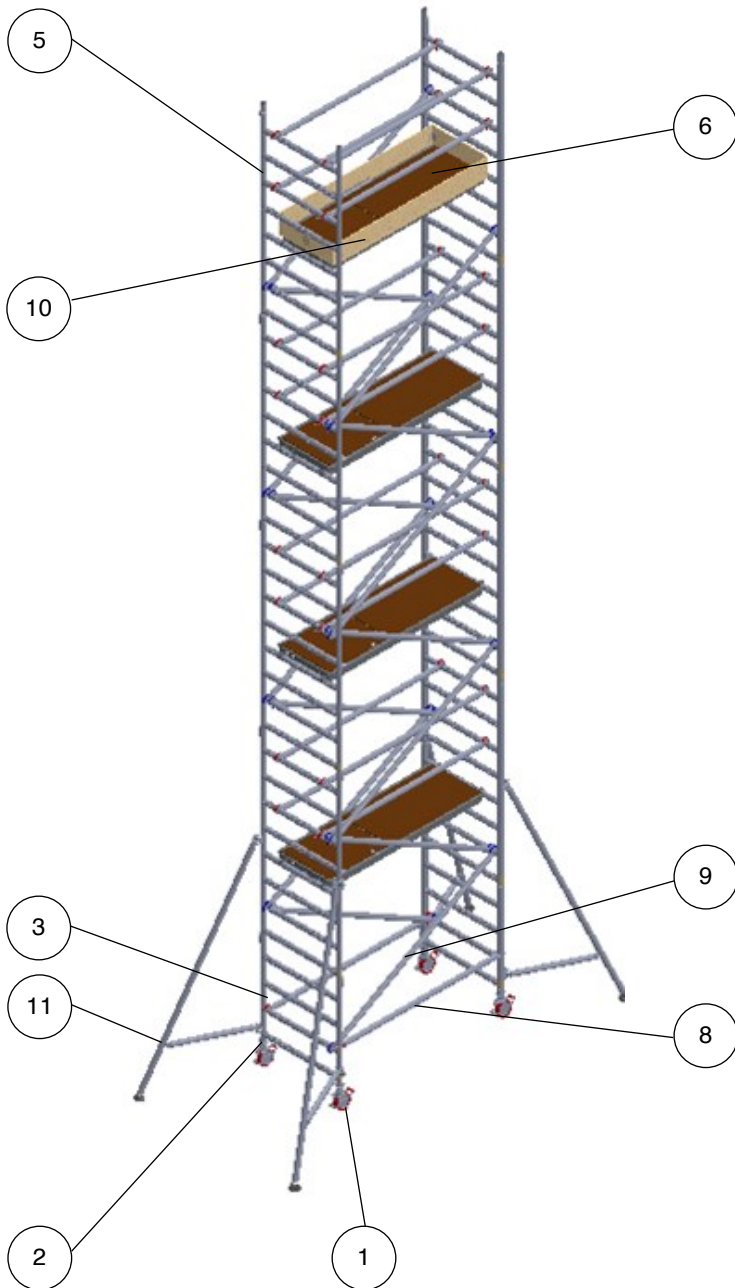

Technical information:

Base Dimensions:	(L)1.8m X (W)0.85m
Maximum Platform Height (ph):	8.2m
Maximum Working Height (wh):	10.2m
Maximum Working Load Per Platform:	275kg
Maximum Working Load Per Tower: (including tower weight)	950kg
Weight:	246.6kg



SERVICE YOU CAN TRUST

Single Width Tower	Working Height	Platform Height
1.8m Long x 0.85m Wide	10.7m	8.7m

Tower Components

Item	Description	Quantity
1	150mm Locking Caster	4
2	Adjustable Leg 500mm	4
3	1m 4 Rung Frame	0
4	1.5m 6 Rung Frame	2
5	2m 8 Rung Frame	8
6	1.8m Trapdoor Platform	5
7	1.8m Fixed Platform	0
8	1.8m Horizontal Brace	18
9	2.1m Diagonal Brace	16
10	Complete Toe Board Set	1
11	S1 Stabiliser	0
12	S2 Stabiliser	4
13	Instruction Manual & EN1004:-1:2020 certificate of conformity	1

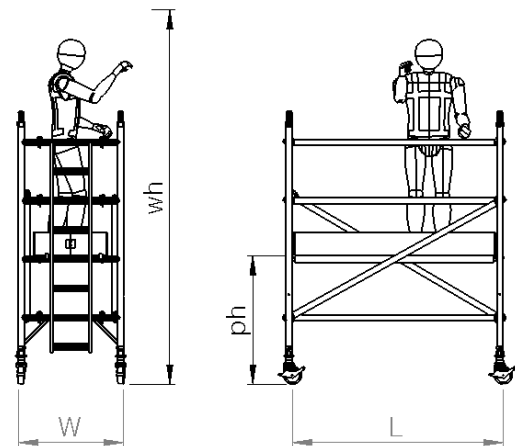
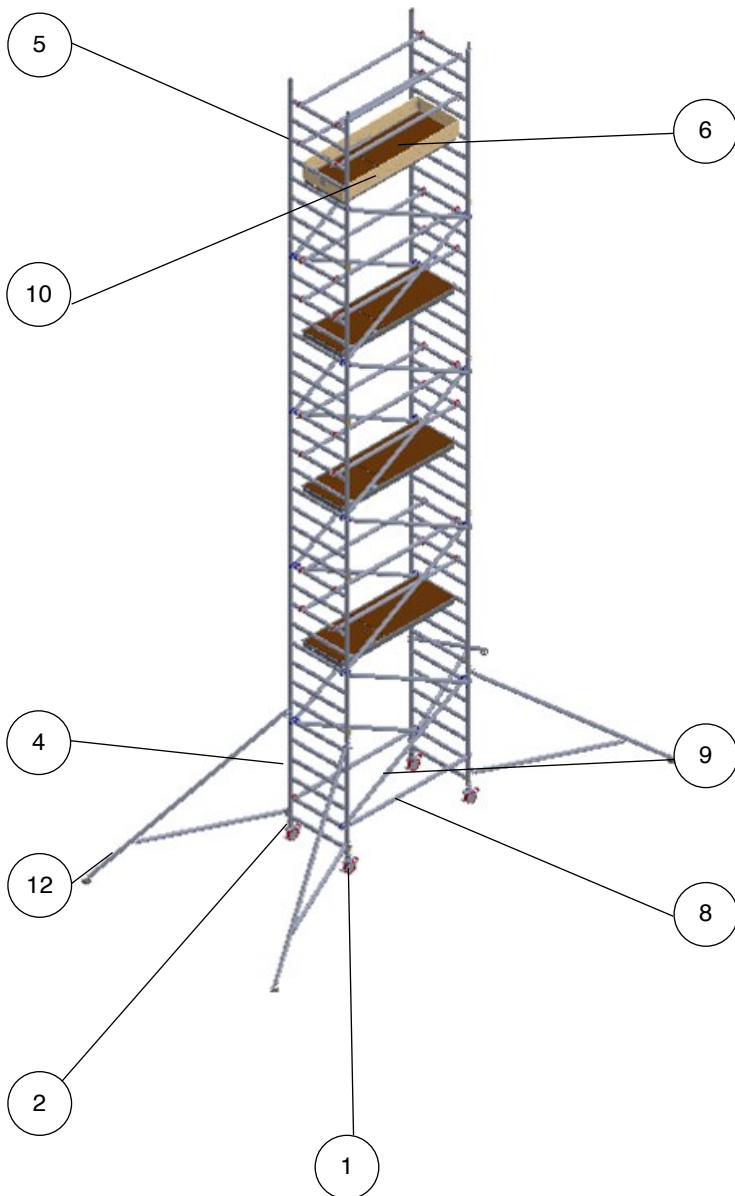

Technical information:

Base Dimensions:	(L)1.8m X (W)0.85m
Maximum Platform Height (ph):	8.7m
Maximum Working Height (wh):	10.7m
Maximum Working Load Per Platform:	275kg
Maximum Working Load Per Tower: (including tower weight)	950kg
Weight:	262.1kg

Mr Plant Hire
120 Hertford Road Enfield
London EN3 5AX

☎ 020 8351 3434
✉ info@mrplanthire.co.uk



Single Width Tower	Working Height	Platform Height
1.8m Long x 0.85m Wide	11.2m	9.2m

Tower Components

Item	Description	Quantity
1	150mm Locking Caster	4
2	Adjustable Leg 500mm	4
3	1m 4 Rung Frame	0
4	1.5m 6 Rung Frame	0
5	2m 8 Rung Frame	10
6	1.8m Trapdoor Platform	5
7	1.8m Fixed Platform	0
8	1.8m Horizontal Brace	22
9	2.1m Diagonal Brace	17
10	Complete Toe Board Set	1
11	S1 Stabiliser	0
12	S2 Stabiliser	4
13	Instruction Manual & EN1004:-1:2020 certificate of conformity	1

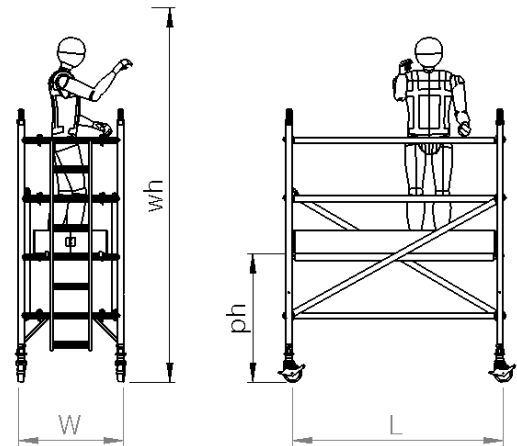
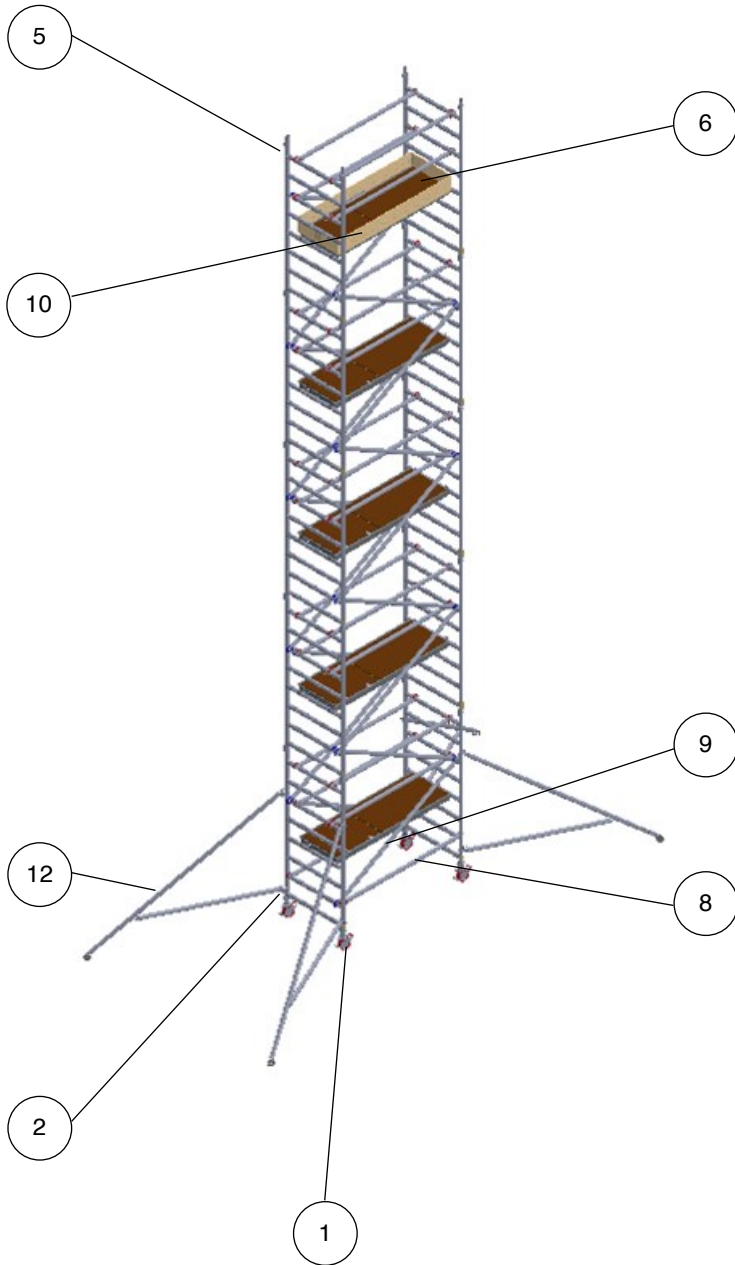

Technical information:

Base Dimensions:	(L)1.8m X (W)0.85m
Maximum Platform Height (ph):	9.2m
Maximum Working Height (wh):	11.2m
Maximum Working Load Per Platform:	275kg
Maximum Working Load Per Tower: (including tower weight)	950kg
Weight:	289.2kg



SERVICE YOU CAN TRUST

Single Width Tower	Working Height	Platform Height
1.8m Long x 0.85m Wide	11.7m	9.7m

Tower Components

Item	Description	Quantity
1	150mm Locking Caster	4
2	Adjustable Leg 500mm	4
3	1m 4 Rung Frame	2
4	1.5m 6 Rung Frame	2
5	2m 8 Rung Frame	8
6	1.8m Trapdoor Platform	5
7	1.8m Fixed Platform	0
8	1.8m Horizontal Brace	22
9	2.1m Diagonal Brace	18
10	Complete Toe Board Set	1
11	S1 Stabiliser	0
12	S2 Stabiliser	4
13	Instruction Manual & EN1004:-1:2020 certificate of conformity	1

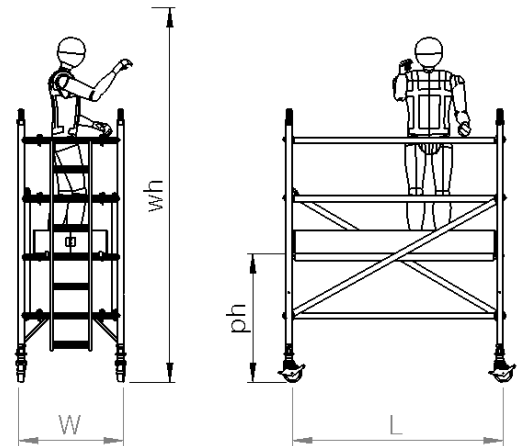
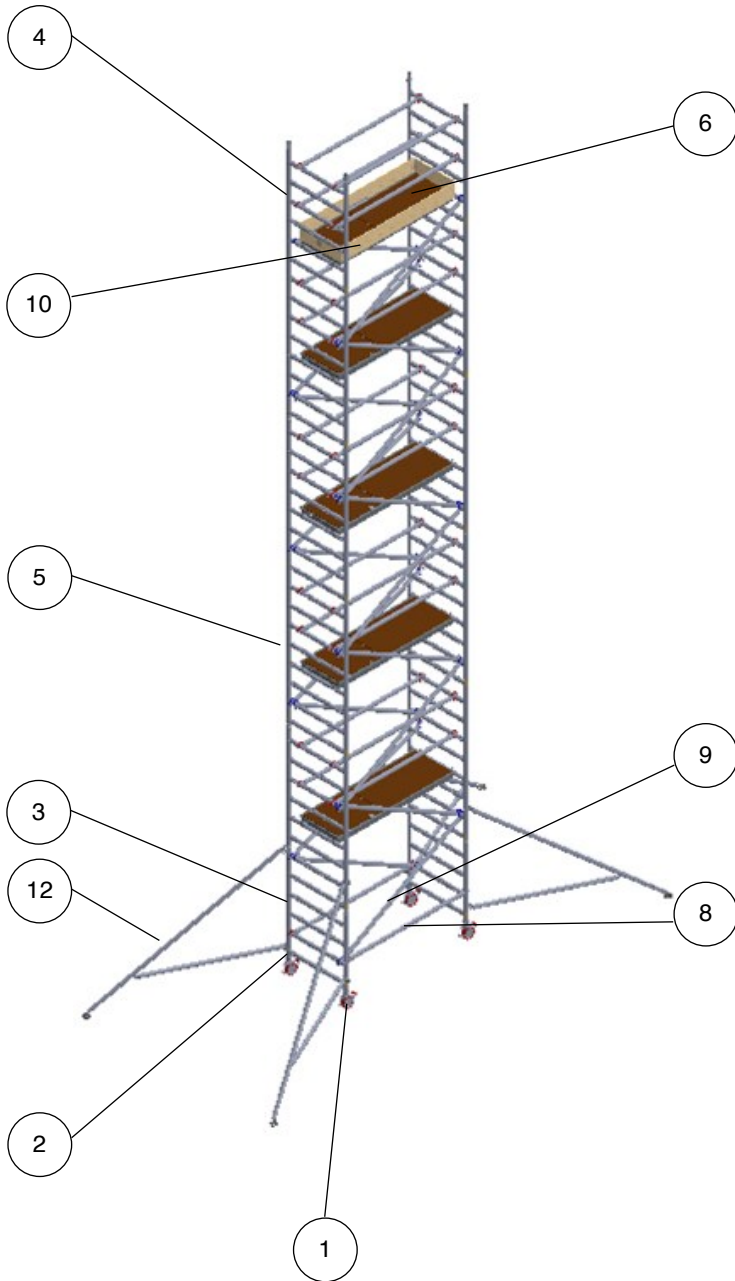

Technical information:

Base Dimensions:	(L)1.8m X (W)0.85m
Maximum Platform Height (ph):	9.7m
Maximum Working Height (wh):	11.7m
Maximum Working Load Per Platform:	275kg
Maximum Working Load Per Tower: (including tower weight)	950kg
Weight:	296.2kg

Mr Plant Hire
120 Hertford Road Enfield
London EN3 5AX

☎ **020 8351 3434**
✉ **info@mrplanthire.co.uk**

BS 8620:2016
TM1005
testandresearch.org

Single Width Tower 1.8m Long x 0.85m Wide	Working Height 12.2m	Platform Height 10.2m
---	--------------------------------	---------------------------------

Tower Components

Item	Description	Quantity
1	150mm Locking Caster	4
2	Adjustable Leg 500mm	4
3	1m 4 Rung Frame	2
4	1.5m 6 Rung Frame	0
5	2m 8 Rung Frame	10
6	1.8m Trapdoor Platform	5
7	1.8m Fixed Platform	0
8	1.8m Horizontal Brace	22
9	2.1m Diagonal Brace	19
10	Complete Toe Board Set	1
11	S1 Stabiliser	0
12	S2 Stabiliser	4
13	Instruction Manual & EN1004:-1:2020 certificate of conformity	1

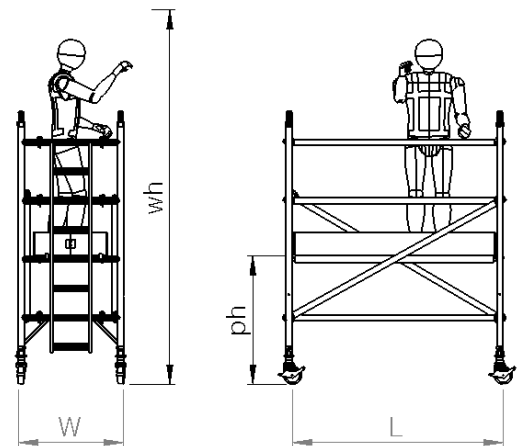
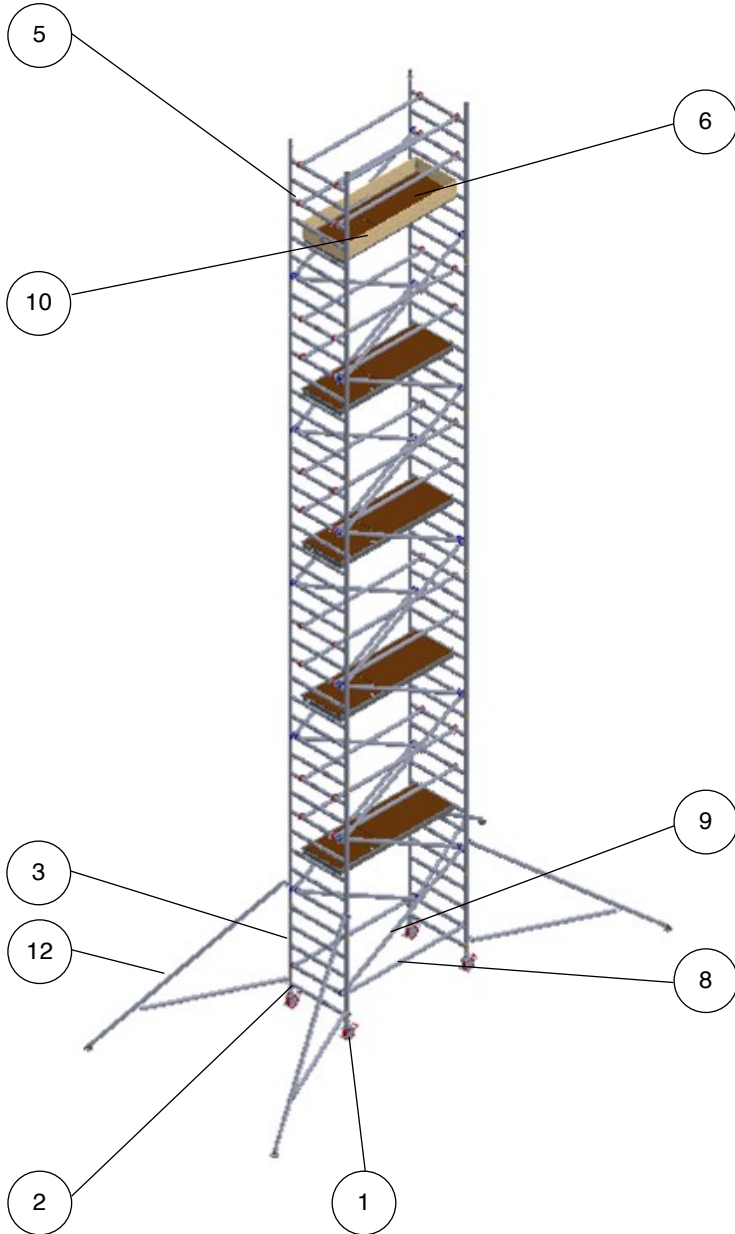

Technical information:

Base Dimensions:	(L)1.8m X (W)0.85m
Maximum Platform Height (ph):	10.2m
Maximum Working Height (wh):	12.2m
Maximum Working Load Per Platform:	275kg
Maximum Working Load Per Tower: (including tower weight)	950kg
Weight:	302.2kg

Single Width Tower 1.8m Long x 0.85m Wide	Working Height 12.7m	Platform Height 10.7m
---	--------------------------------	---------------------------------

Tower Components

Item	Description	Quantity
1	150mm Locking Caster	4
2	Adjustable Leg 500mm	4
3	1m 4 Rung Frame	0
4	1.5m 6 Rung Frame	2
5	2m 8 Rung Frame	10
6	1.8m Trapdoor Platform	6
7	1.8m Fixed Platform	0
8	1.8m Horizontal Brace	22
9	2.1m Diagonal Brace	20
10	Complete Toe Board Set	1
11	S1 Stabiliser	0
12	S2 Stabiliser	4
13	Instruction Manual & EN1004:-1:2020 certificate of conformity	1

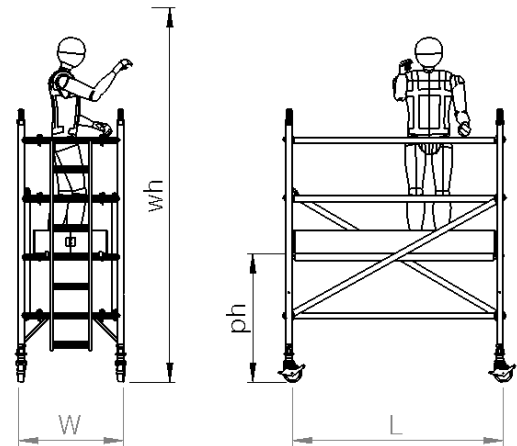
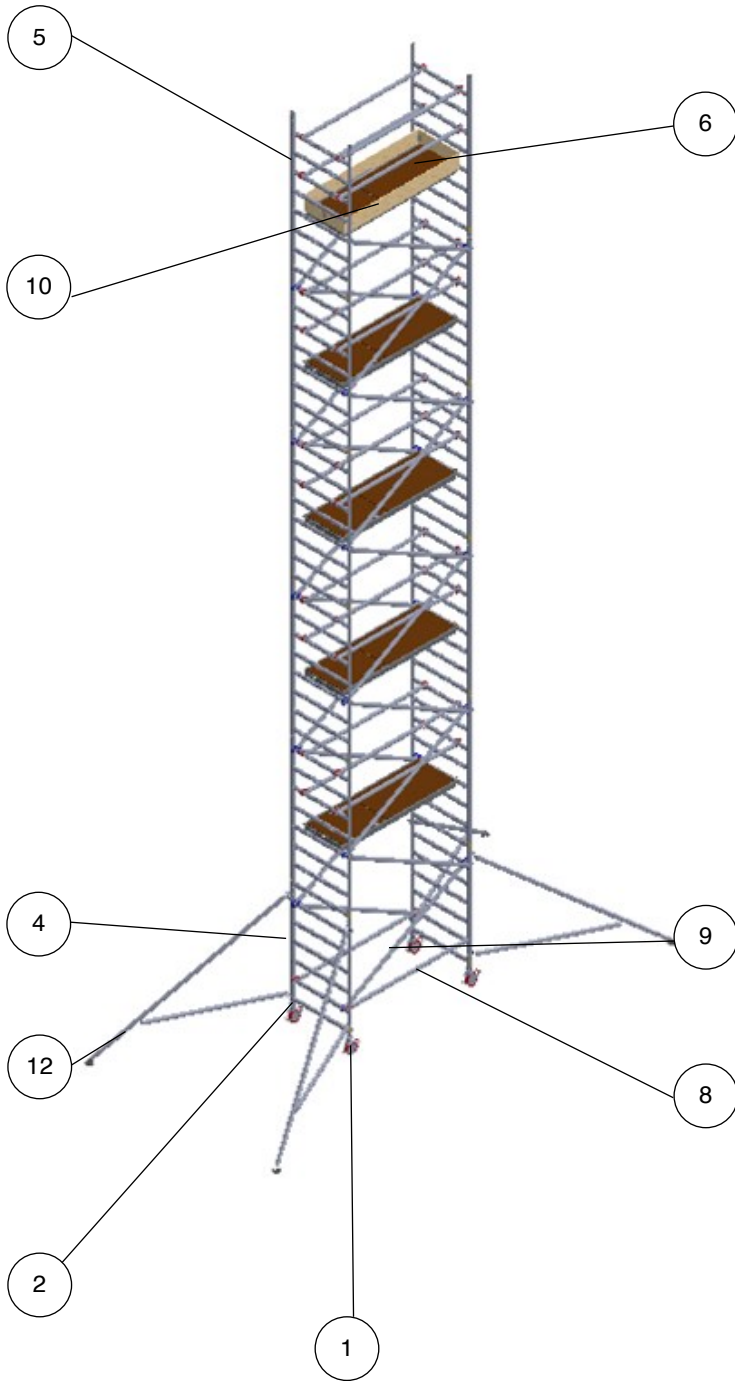

Technical information:

Base Dimensions:	(L)1.8m X (W)0.85m
Maximum Platform Height (ph):	10.7m
Maximum Working Height (wh):	12.7m
Maximum Working Load Per Platform:	275kg
Maximum Working Load Per Tower: (including tower weight)	950kg
Weight:	310.5kg

Single Width Tower 1.8m Long x 0.85m Wide	Working Height 13.2m	Platform Height 11.2m
---	--------------------------------	---------------------------------

Tower Components

Item	Description	Quantity
1	150mm Locking Caster	4
2	Adjustable Leg 500mm	4
3	1m 4 Rung Frame	0
4	1.5m 6 Rung Frame	0
5	2m 8 Rung Frame	12
6	1.8m Trapdoor Platform	6
7	1.8m Fixed Platform	0
8	1.8m Horizontal Brace	26
9	2.1m Diagonal Brace	21
10	Complete Toe Board Set	1
11	S1 Stabiliser	0
12	S2 Stabiliser	4
13	Instruction Manual & EN1004:-1:2020 certificate of conformity	1

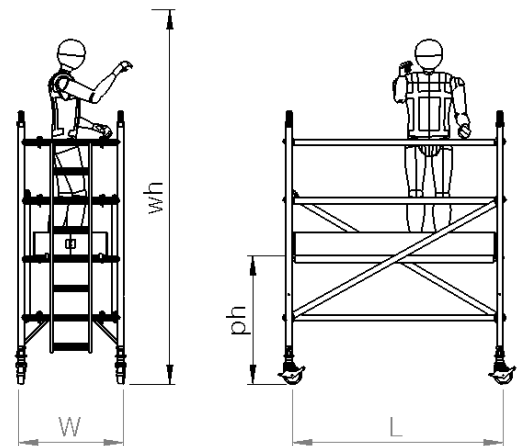
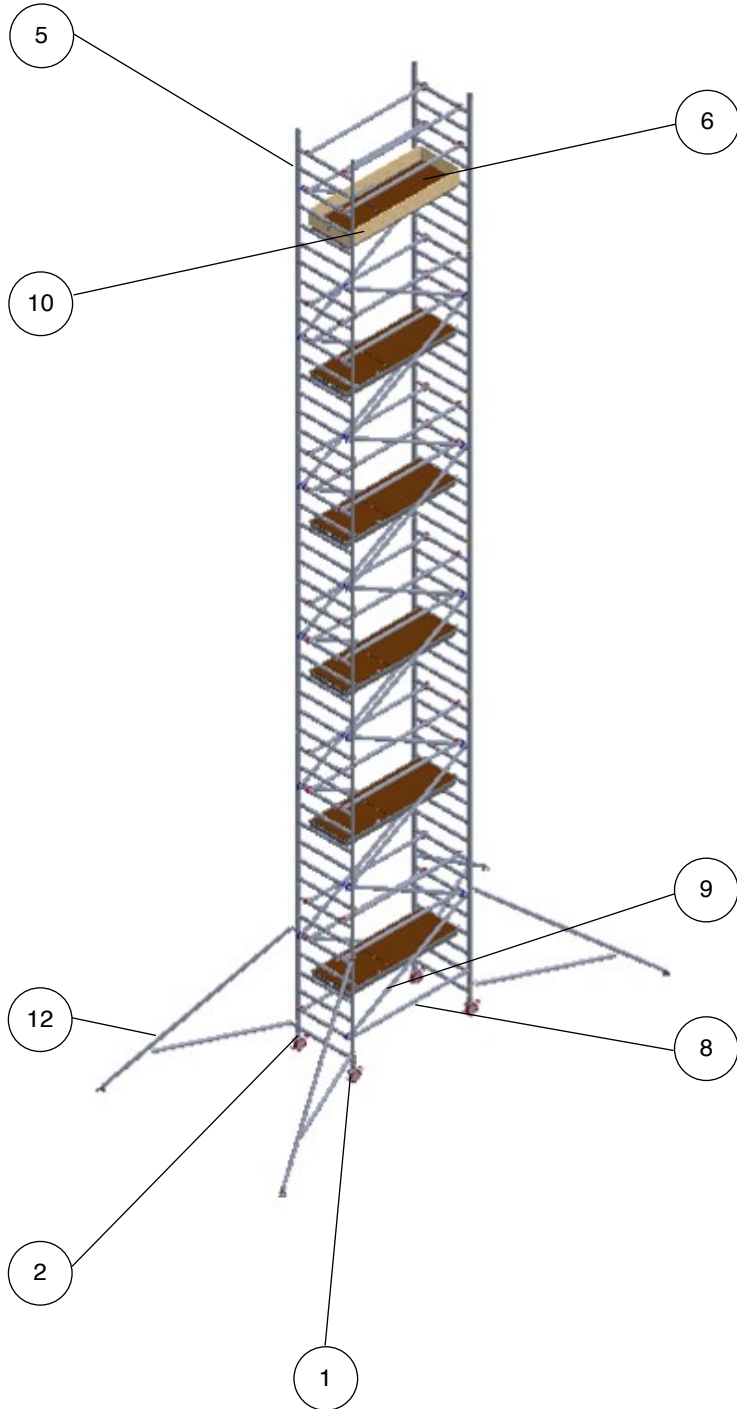

Technical information:

Base Dimensions:	(L)1.8m X (W)0.85m
Maximum Platform Height (ph):	11.2m
Maximum Working Height (wh):	13.2m
Maximum Working Load Per Platform:	275kg
Maximum Working Load Per Tower: (including tower weight)	950kg
Weight:	337.6kg

Single Width Tower	Working Height	Platform Height
1.8m Long x 0.85m Wide	13.7m	11.7m

Tower Components

Item	Description	Quantity
1	150mm Locking Caster	4
2	Adjustable Leg 500mm	4
3	1m 4 Rung Frame	2
4	1.5m 6 Rung Frame	2
5	2m 8 Rung Frame	10
6	1.8m Trapdoor Platform	6
7	1.8m Fixed Platform	0
8	1.8m Horizontal Brace	26
9	2.1m Diagonal Brace	22
10	Complete Toe Board Set	1
11	S1 Stabiliser	0
12	S2 Stabiliser	4
13	Instruction Manual & EN1004:-1:2020 certificate of conformity	1

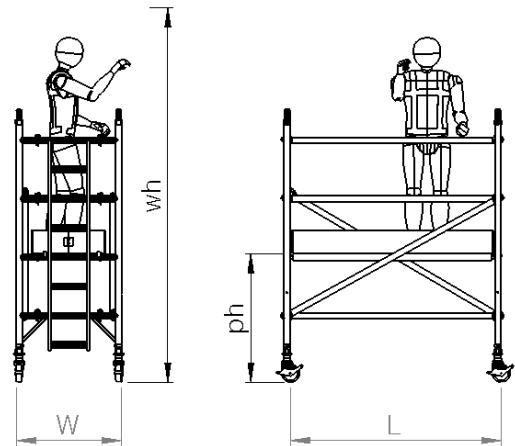
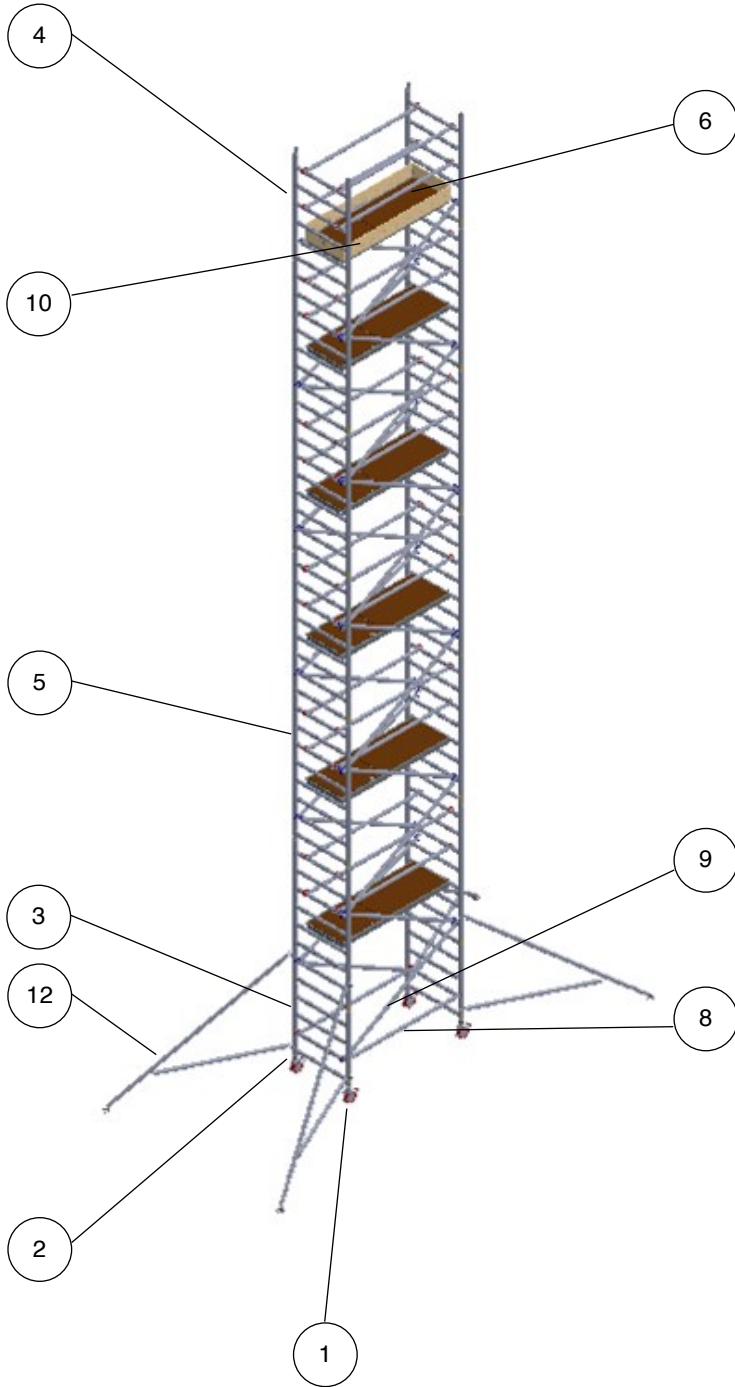

Technical information:

Base Dimensions:	(L)1.8m X (W)0.85m
Maximum Platform Height (ph):	11.7m
Maximum Working Height (wh):	13.7m
Maximum Working Load Per Platform:	275kg
Maximum Working Load Per Tower: (including tower weight)	950kg
Weight:	344.6kg

Single Width Tower	Working Height	Platform Height
1.8m Long x 0.85m Wide	14.2m	12.2m

Tower Components

Item	Description	Quantity
1	150mm Locking Caster	4
2	Adjustable Leg 500mm	4
3	1m 4 Rung Frame	2
4	1.5m 6 Rung Frame	0
5	2m 8 Rung Frame	12
6	1.8m Trapdoor Platform	6
7	1.8m Fixed Platform	0
8	1.8m Horizontal Brace	26
9	2.1m Diagonal Brace	23
10	Complete Toe Board Set	1
11	S1 Stabiliser	0
12	S2 Stabiliser	4
13	Instruction Manual & EN1004:-1:2020 certificate of conformity	1

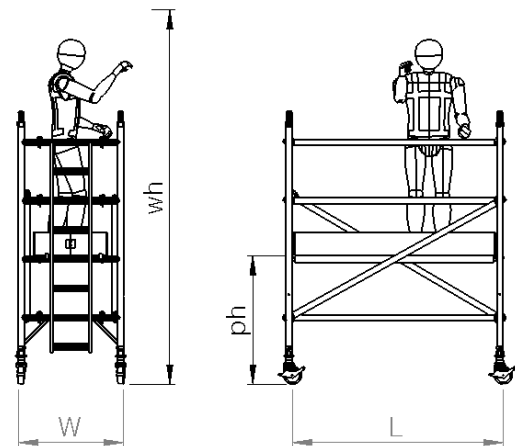
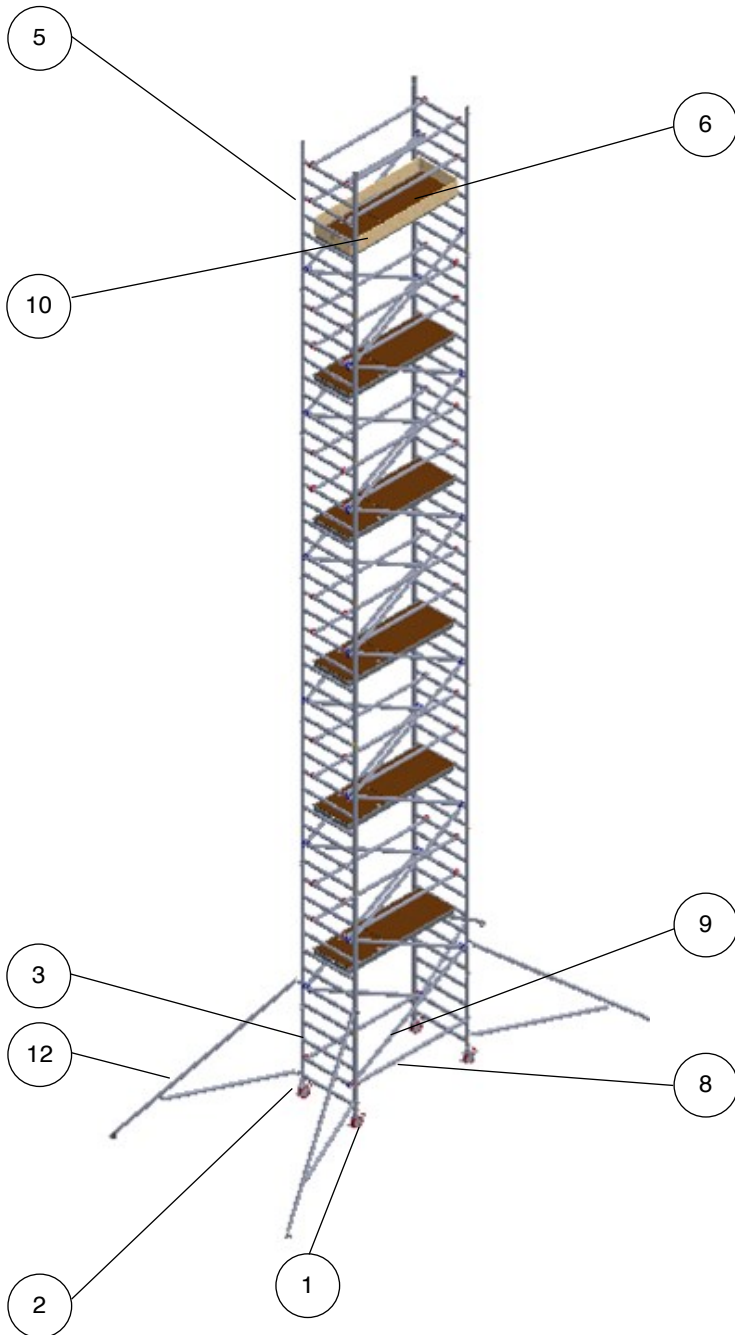

Technical information:

Base Dimensions:	(L)1.8m X (W)0.85m
Maximum Platform Height (ph):	12.2m
Maximum Working Height (wh):	14.2m
Maximum Working Load Per Platform:	275kg
Maximum Working Load Per Tower: (including tower weight)	950kg
Weight:	350.6kg